

Blue Vision 2011 ig Orange Vision 2011 ig

(ig – injection gas*)

- * – gas alternative – natural gas G20 or bottled gas G30
- optional flue gas exhaust A3 (without chimney) or B13 (with chimney)

retigo®
Vision

- **VISION DESIGN** – Remarkable attractiveness and functionality
- **VISION TOUCH** – Control touch panel – simple, fast, intuitive
- EcoLogic system – Energy recuperation – energy savings
- Retigo control philosophy – Maximal comfort for Chefs
- Turbo steam function – Fresh steam boost for the best steaming
- Massive door handle – Comfortable and safe manipulation
- Curved double glass door – No more burns and energy losses
- Unique cooking chamber finishing – Longer lifetime more hygiene
- AISI 304 only as a matter of fact – No corrosion risks
- Cross-wise racks – No burn wrists, better visual control
- Bi-directional fan – Excellent cooking and baking evenness
- Perfect halogen illumination – Precise visual control
- Run-off tray under the door – No slipping on water
- Removable door seal – Easy maintenance
- WSS - water saving system – Minimized water consumption
- Integrated shower – Easy cleaning, no fighting with winding up
- SDS – service and diagnostic system – Lower service costs, time
- IPX5 shield – Maximal safety in kitchen environment
- Instant HACCP records – Food quality ensured
- Extra tray – Enhanced capacity
- Loading trolley



GENERAL CHARACTERISTICS

B 2011 ig

- **EASY COOKING** – Instant&Simple cooking with new technology
- **VISION AGENT** – Virtual help at your finger tip
- **ACTIVE CLEANING** – Less money&time - higher hygiene level
- **ACTIVE DESCALER** – Automatic cooking chamber descaling
- Big Color touch screen controls – simplicity in practice
- Hot air 30–300 °C
- Combination 30–300 °C
- Steaming 30–130 °C
- 4 point temperature core probe – Food core under control
- Delta T cooking, steaming – Excellence with big food chunks
- Low temperature roasting – Lower weight lost, better taste
- Overnight cooking / baking – Saves time and money
- Cook & Hold – Time savings in kitchen
- Regeneration/Banqueting – Serve more in shorter times
- Programming – Easy to operate (1000 programs/20 steps)
- Pictograms, Touch&Cook – Just double touch for cooking
- Vision Chef – Instant food preparation and cooking advisor
- 5 speed ventilator with auto reverse system – No limits in your cooking
- Ventilator fan timing – 3 steps for greater evenness
- Rack timing - Different products cooked at once
- Learn function – Improves cooking standards every time
- Fan Stop – Prevents scalding when door opened quickly
- Automatic preheating/cooling – Compensates loading Temp. drops
- Autoclimate – steam saturation control (1 % precision) for the best results
- Automatic start – Helps to reduce idles and save your time
- QuickView – fast program overview – Easy orientation in steps
- Golden Touch – Controlled finishing for crispy and brown excellence
- ACM (Automatic Capacity Management) – Adjusts to the best cooking
- Energy logic – Energy costs under your control, consumption displayed
- USB Plug-in, LAN interface – Saves your time with managing data

UNIT OPTIONS

- Safety door opening in two steps
- Software to manage HACCP data and recipes free of charge

O 2011 ig

- Digital control display with touch controls – Simplicity
- Autoclimate – steam saturation control (1 % precision) for the best results
- Hot air 30–300 °C
- Combination 50–300 °C
- Steaming 99–130 °C
- Regeneration/Banqueting – Serves more in shorter times
- Programming – 99 programs with 9 steps
- 1 point temperature core probe – Food core under control
- 1 speed ventilator with Auto reverse system – Evennes controlled
- Automatic preheating/cooling – Compensates loading Temp. drops
- ACM (Automatic Capacity Management) – Adjusts to the best cooking
- Automatic start – Helps to reduce idles and save your time
- USB Plug-in, LAN interface – Saves your time with managing data

UNIT OPTIONS

- Flap valve
- 5 ventilator speeds + Fan stop function
- Safety door opening in two steps
- Software to manage HACCP data and recipes free of charge

MODEL CHARACTERISTICS

ACCESSORIES

VO 2011 R	- spare loading trolley
VO 2011 B	- banquet trolley for 48 or 59 plates
LOADING RAMP 2011	
TO 2011	- thermocover for trolley VO 2011 R, B
VO 1511R	- loading trolley with 15 trays with 85 mm spacing

FEET FITTING MEANS
HANDLE MOUNT FOR LOADING TROLLEY
OIL SPRAY GUN

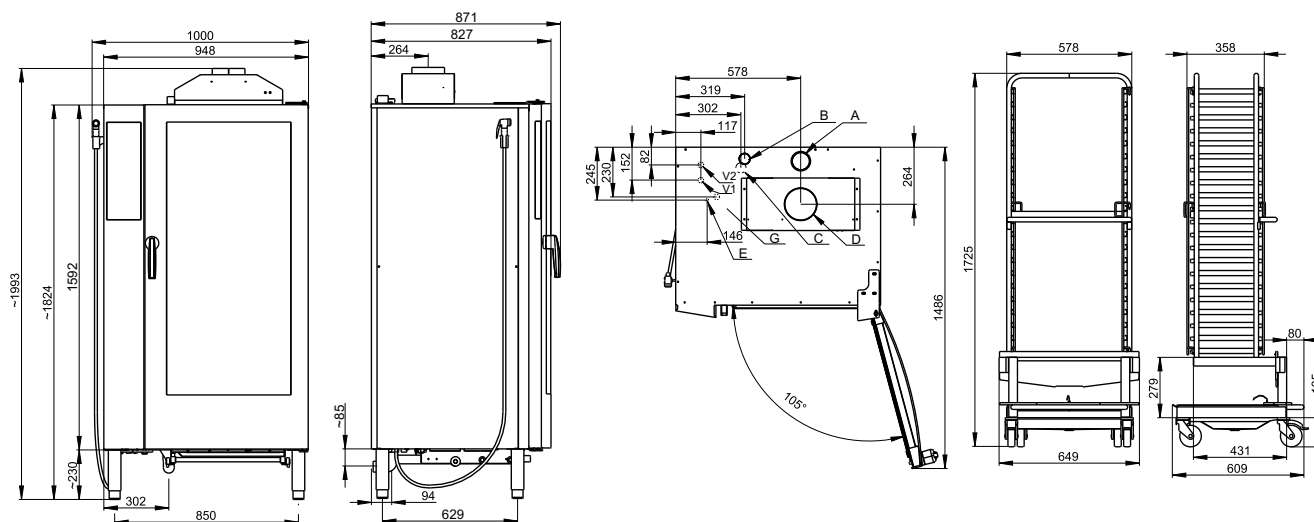

A – Flap valve, B – Chimney, C – Drain, E – Electricity, G – Gas, V1 – Untreated water, V2 – Treated water

B 2011 ig / O 2011 ig

Energy	gas
Steam generation	injection
Capacity	21 trays GN1/1
Capacity of meals	400–600
Spacing [mm]	60
Dimensions (W x H x D) [mm]	948 x 1993 x 871
Weight	226 kg
Heat power	38 kW
Total power	1,4 kW
Steam generation power	3,9 m ³ /hr.
Fuse protection	10 A
Voltage	1 N~/230 V/50 Hz
Water connection / drain [mm]	G 3/4" / 50
Gas connection	G 3/4"
Temperature	30–300 °C

SIZE	MODEL	TECHNICAL SPECIFICATION
2011	B2011ig, O2011ig	G2011IA, G2011IZ